

Note: The answers can be given either in English or Finnish.

Question 1. Define shortly the following terms or concepts relevant to switched-mode converters **a)** Vs balance, **b)** As balance, **c)** M(D,K), **d)** K_{crit} **e)** BCM and **f)** PFC (**Note:** Direct English language translation is not enough but the meanings are required to be explained!) Each subquestion gives 1 pt.

Question 2. Fig. 1 shows a sample of the inductor current of an ideal buck converter. In addition with the inductor-current waveform (Fig. 1), we know that its input voltage is 50 V. **a)** What is its operation mode (CCM, BCM, DCM)?, **b)** What is its average output current?, **c)** What is its output voltage?, **d)** What is its duty ratio?, **e)** What is the value of its inductor L, and **f)** What is its average output capacitor current? Each subquestion gives 1 p.

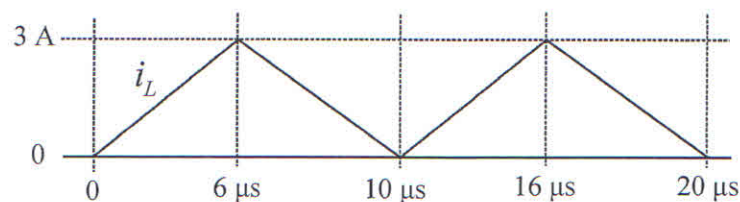

Fig. 1

Question 3. Fig. 2 shows the power stage of a boost converter having switching frequency f_s of 150 kHz. Its critical K_{crit} value is DD'^2 . Assume the diode D_1 to be ideal. **a)** Choose the value of the inductor L_{in} such that the converter operates in DCM when the output voltage and output power are 50 V and 50 W and the input voltage varies in the range of 12-40 V (3 pts). **b)** Define of the value of pulse ratio when the output voltage and output power are as defined above and the input voltage equals 30 V (2 pts). **c)** Define the peak-to-peak ripple current of the inductor at the operating point of **b)** (1pts). $D = \sqrt{KM(M-1)}$, $K = \frac{2L}{R_{eq}T_s}$, $M(D) = 1/D'$.

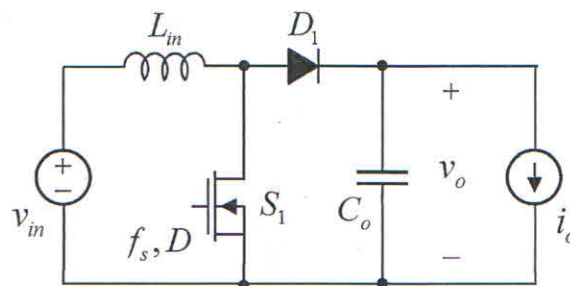

Fig. 2

Question 4. The switching frequency of the Flyback converter in Fig. 3 is 150 kHz, and it is operating in DCM. Its input voltage $V_{in} = 350$ V, output voltage $V_o = 48$ V, transformer turns ratio $n_2/n_1 = 0.21$, $L_M = 2$ mH, $C_o = 330$ μ F, and output power $P_o = 40$ W. The duty ratio is defined by $D = \sqrt{K} \cdot M$ and the critical K by D'^2 . Assume the output diode D_1 to be ideal. Define a) the maximum voltage of the switch S_1 , b) the maximum voltage of the diode D_1 , c) the K value of the converter, d) the duty ratio, e) the peak current of S_1 , and f) the average current of the diode D_1 . Each subquestion gives 1 pt.

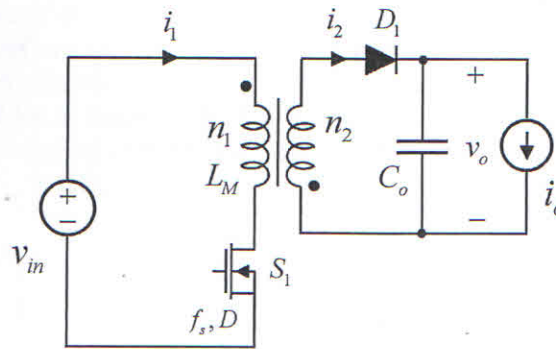

Fig. 3

Question 5. An active reset Forward converter is shown in Fig. 4. The converter works in such a way that the main switch S_1 conducts during the on time, and the auxiliary switch S_2 during the off time, respectively. The input voltage is 200 V, the switching frequency is 100 kHz, and the magnetizing inductance is 4 mH, respectively. The active reset capacitor is large enough so that its voltage can be assumed constant. The absolute maximum voltage of the MOSFET S_1 is 600 V. Derating of 15 % is required for reliability reasons. This question gives maximally 8 pts.

- a) Compute the steady-state voltage v_{CR} as a function of the input voltage and the duty ratio D of the MOSFET S_1 applying Vs concept to the magnetizing inductor. (3 pts)
- b) What is the maximum allowed duty ratio D ? (2 pts)
- c) Sketch the waveform of the magnetizing current i_{LM} and compute its peak value when the duty ratio is the allowed maximum. (3 pts)

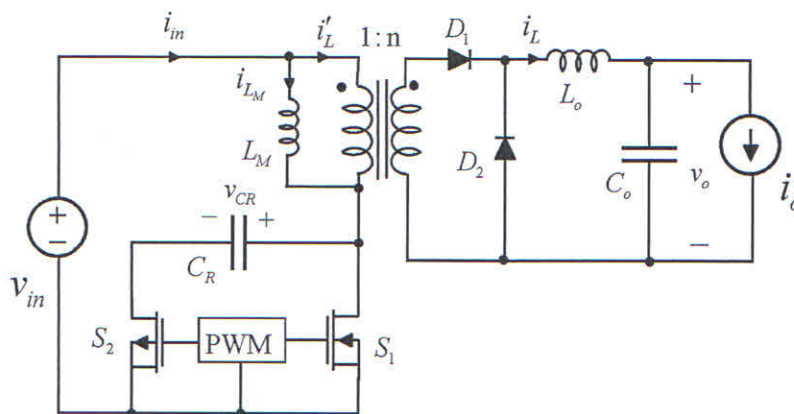

Fig. 4